

MODEL PAD 35-20
REGULATED DC POWER SUPPLY
OPERATION MANUAL

KIKUSUI ELECTRONICS CORP

71.1.25

Power Requirements of this Product

Power requirements of this product have been changed and the relevant sections of the Operation Manual should be revised accordingly.

(Revision should be applied to items indicated by a check mark)

Input voltage

The input voltage of this product is _____ VAC,
and the voltage range is _____ to _____ VAC. Use the product within this range only.

Input fuse

The rating of this product's input fuse is _____ A, _____ VAC, and _____.

WARNING

- To avoid electrical shock, always disconnect the AC power cable or turn off the switch on the switchboard before attempting to check or replace the fuse.
- Use a fuse element having a shape, rating, and characteristics suitable for this product. The use of a fuse with a different rating or one that short circuits the fuse holder may result in fire, electric shock, or irreparable damage.

AC power cable

The product is provided with AC power cables described below. If the cable has no power plug, attach a power plug or crimp-style terminals to the cable in accordance with the wire colors specified in the drawing.

WARNING

- The attachment of a power plug or crimp-style terminals must be carried out by qualified personnel.

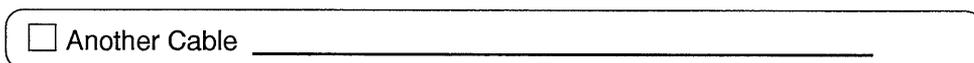
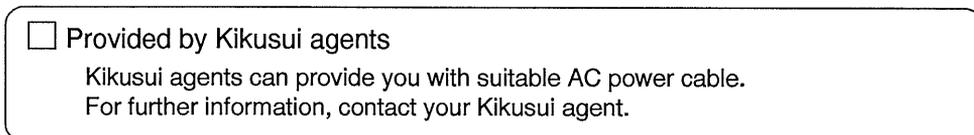
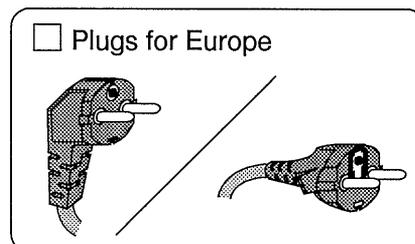
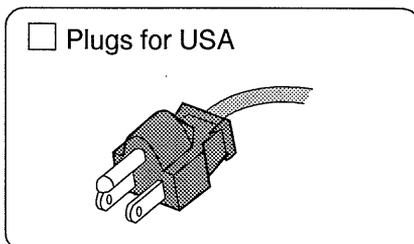
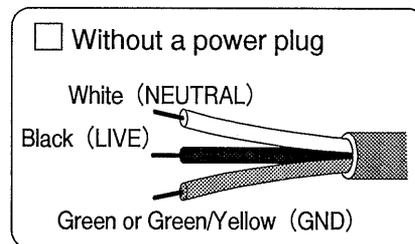
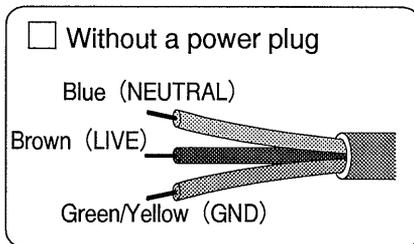

MODEL PAD35-20 TEXT CORRECTIONS

PAGE 9

(12) Power supply connector Attached connector is inserted.

Change (12) Rear terminal plate (3) Input and GND terminals are provided on it.

PAGE 10 Fig. 3-2 Rear panel

Change

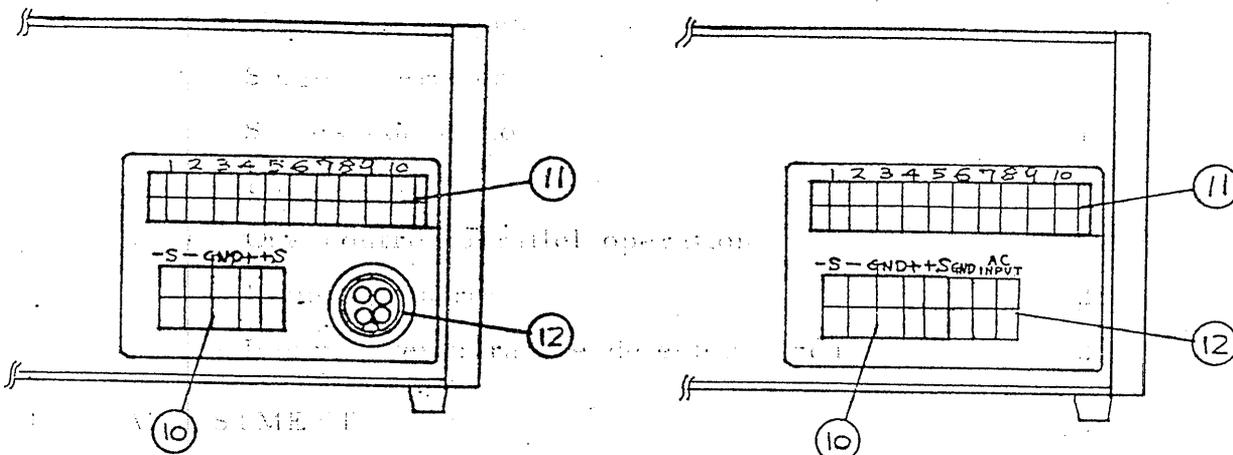

CIRCUIT DIAGRAM

Change

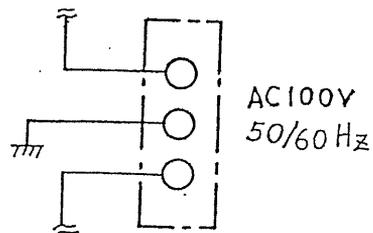
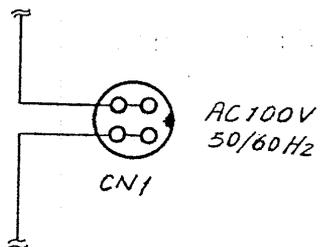

CONTENTS

	Page
1. GENERAL DESCRIPTION	3
2. SPECIFICATION	5
3. OPERATION	8
3. 1 Front Panel Description	8
3. 2 Precaution	10
3. 3 How to use sampling terminals	11
3. 4 Constant-voltage, current characteristics	13
3. 5 Transient response	14
3. 6 Single operation	15
3. 7 Series connection	17
3. 8 Parallel connection	19
3. 9 One control parallel operation	20
3.10 Remote control	22
3.11 Internal temperature detector circuit	25
4. ADJUSTMENT	26
4. 1 Adjustment for max. output voltage	26
4. 2 Adjustment for max. output current	26
4. 3 Adjustment of voltage across the collector and the emitter	26
* BLOCK DIAGRAM	

1. GENERAL DESCRIPTION

Kikusui Electronics' Model PAD 35-20 is an all-silicon-transistorized, highly reliable, variable regulated DC power supply which has excellent regulation, a low temperature coefficient and fast transient response. It is a universal type usable for either a digital or analog circuit. Since a pre-regulated circuit is built-in, overheating of the entire instrument is suppressed. Therefore, the instrument is compact and light-weight in comparison with the conventional instruments although it is of natural cooling type.

The output voltage is adjustable precisely and smoothly over a range of zero to 35V with a 5-turn vernier type variable resistor.

The maximum output current is 20A. Model PAD 35-20 can be used as a constant current power supply over a range of 0.5 to 20A.

Use of a new circuit technique permits the constant current characteristic to be improved largely, as compared with the conventional type.

Model PAD35-20 is a constant voltage-current automatic crossover type in which the constant output voltage performance and constant current performance are changed over automatically according to load variation.

Two lamps mounted on the front panel indicate the respective operation modes alternately (constant voltage or constant current).

Model PAD35-20 is not only used in single operation but in series, parallel or one-control parallel¹ operation by which the voltage or current can be expanded. Use of an external resistor also permits the output voltage to be remote-controlled.

2. SPECIFICATIONS

AC input	----- V AC \pm 10%, 50/60 Hz
Full load	Approximately 1.6 kVA
Dimensions	Case 430W x 160H x 400D mm*
Maximum	430W x 175H x 490D mm
Weight	Approximately 30 kg
Ambient temperature	0 ~ 40°C
Accessories supplied	Short bar (long) 1 (Short) 2 Fuse 20A 2 Operation manual 1
Output	
Terminals	Color coded, aligned horizontally; 5 terminals on the rear panel (-sampling, -, GND, +, +sampling; Obtainable from the front and rear panels.
Polarity	Positive or negative
Floating voltage	\pm 150V maximum
Air-cooling system	By natural convection
Constant voltage characteristics;	

Voltage	0 ~ 35V continuously variable with 5-turn variable resistor.
Current	20A
Ripple noise (5 Hz ~ 1 MHz)	500 μ V rms
Voltage regulation (At sampling terminals)	
Line regulation	0.005% + 1 mV against $\pm 10\%$ variation of line voltage
Load regulation	0.005% + 2mV against 0 - 100% variation of output current
Transient response (10 ~ 100%)	Typical value 100 μ s
Temperature coefficient	Typical value 100PPM/ $^{\circ}$ C
Constant current characteristics;	
Voltage	0 ~ 35V continuously variable with 5-turn variable resistor
Current	0.5 ~ 20A continuously variable
Ripple noise (5Hz ~ 1MHz)	3mA rms
Current regulation	
Line regulation	1mA against $\pm 10\%$ variation of line voltage
Load regulation	3mA against 0 ~ 100% variation of output voltage

3. OPERATION

3.1 Front Panel Description (See Fig. 3-1)

- | | |
|------------------------------------|-------------------------------------------------------------------------------------------------------------------------------------------------------------------------------------------|
| ① POWER switch | ON/OFF switch for the input power. Throw it upwards, and the power is on. An electromagnetic switch (breaker) is used for automatically interrupting the power supply in case of failure. |
| ② Pilot lamp | Lights when the power is on. |
| ③ Constant voltage indicating lamp | Lights when Model PAD35-20 ^{is} in the constant voltage mode; C.V |
| ④ Constant current indicating lamp | Lights when Model PAD35-20 is in the constant current mode; C.C |
| ⑤ VOLTAGE | Knob for setting the output voltage. Clockwise rotation increases the output voltage. |
| ⑥ CURRENT | Knob for setting the output current. Clockwise rotation increases the output current. |

- ⑦ Voltmeter indicates the output voltage.
DC 35V.
Accuracy is 2.5% of the full scale.
- ⑧ Ammeter Indicates the output current.
DC 22A.
Accuracy is 2.5% of the full scale.
- ⑨ Output terminals Spaced 19 mm equally and aligned^{gn}
in the following order; from the left,
-SAMPLING(white), (white), GND(black),
+(red). +SAMPLING(red).
- ⑩ Rear terminal plate (1) Output terminals, sampling
terminals, GND terminals are
provided on it.
- ⑪ Rear terminal plate (2) Remote control terminal and one-
control paralld operation terminals
are provided on it.
- ⑫ Power supply connector Attached connector is inserted.

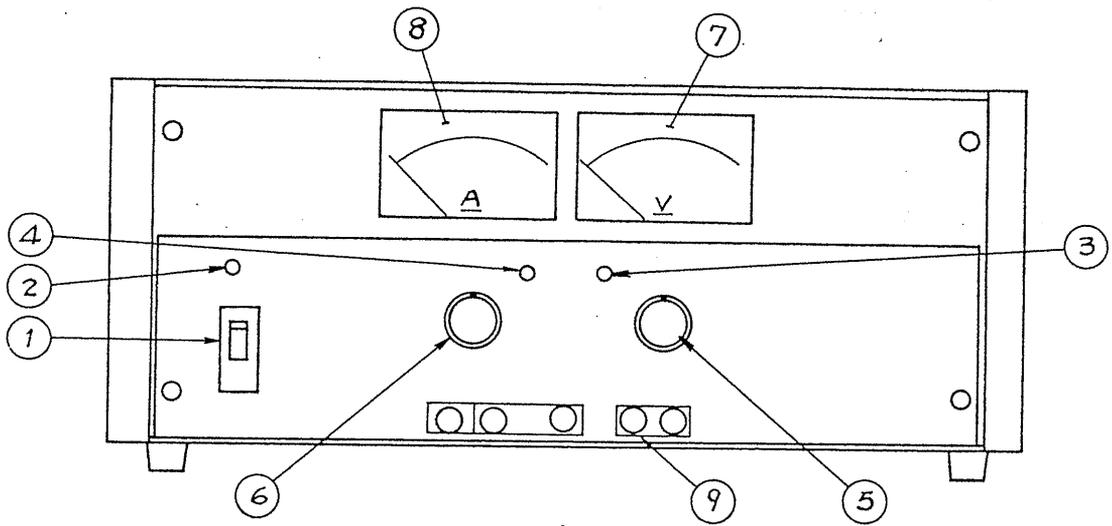

Fig. 3-1 Front Panel

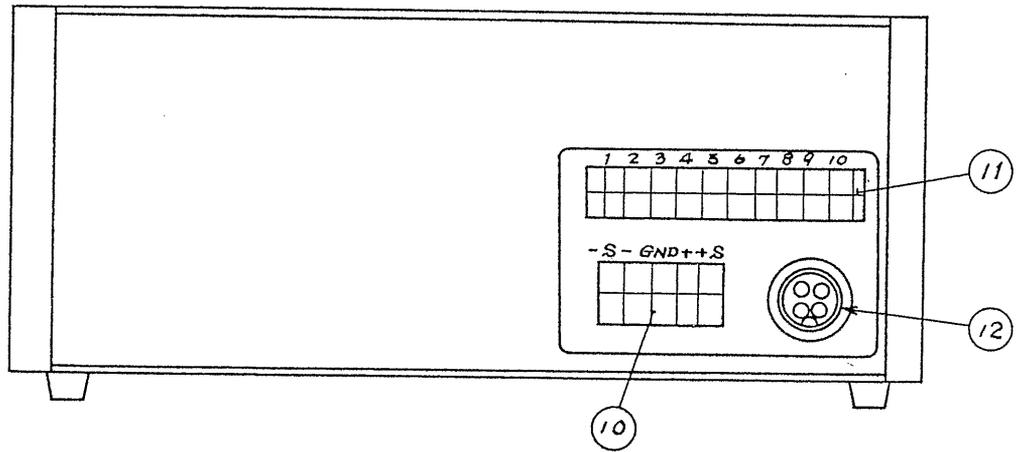

Fig. 3-2 Rear Panel

3.2 Precaution

AC input

AC input for Model PAD 35-20 should be within a range of

----- V AC \pm 10%, 48 ~ 62 Hz.

Installation

Avoid using Model PAD35-20 at a place exposed to heat; where the ambient temperature exceeds a range of zero to 40°C; that is humid or dusty; where it is not be level.

During operation, don't lay Model PAD35-20 on its side nor put anything on it. Otherwise, a fault may be caused by reduction of its radiation effect.

Variable knob output voltage

The vernier type variable resistor for adjusting the output voltage of Model PAD35-20 is endless. When rotated more than five turns, its motion will become considerably rough. This shows the ultimate position of electrical variation.

Output voltage overshoot

Voltage between output terminals never exceeds the preset value when the power is turned on or off.

3.3 How to use sampling terminals

When Model PAD35-20 is far from the load, a long lead connecting the output terminals and the load causes load

regulation to be deteriorated because of voltage drop due to lead resistance.

The sampling terminals serve to solve this trouble. For the connection diagram, see Fig. 3-3.

1. Disconnect the short bars from -SAMPLING, - and +, and + SAMPLING terminals on the front panel.

Remove the jumpers between -S, - and +, and +S terminals on the rear terminal board (1).

2. Connect the output terminals on the rear or front panel to the load. Connect the sampling terminals and the nearest load terminals with other leads.

Match the polarity of the sampling terminals to that of the output terminals.

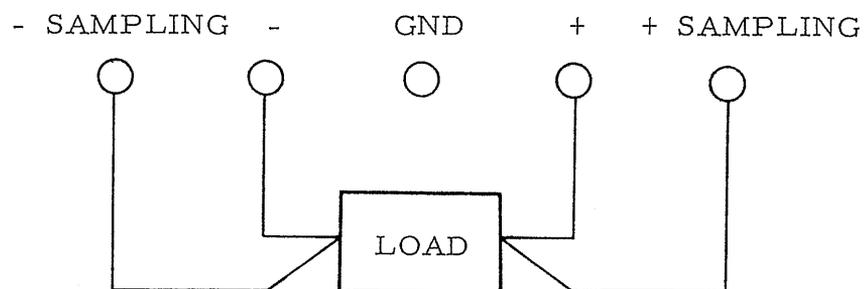

Fig. 3-3

Note 1 Deterioration of load regulation is calculated by the following formula;

$$V_d = I_o \times R \text{ (m}\Omega\text{)}$$

where

I_o (A) = Load current, R (m Ω) = lead resistance

V_d = Voltage drop

Note 2 Use two-conductor shielded wire for sampling to avoid induction causing ripple from outside. Check the sampling leads for proper polarity.

Note 3 Be careful since the lead connected to the load affects the preset constant current value due to its resistance.

Note 4 As long sampling leads tend to cause oscillation, connect electrolytic^{ti} condenser with a capacitance of a few μ F's and a dielectric strength of 50 V to sampling terminals in the proper polarity.

Note 5 Sampling is impossible if voltage drop of the lead connected to the load is 0.3V or more.

3.4 Constant-voltage, current characteristics

The working output characteristic of Model PAD35-20, called constant-voltage/constant-current automatic crossover type,

permits continuous transition from constant-current to constant-voltage operation mode in response to the load change

The intersection of constant-voltage and constant-current operation modes is called crossover point. Fig. 3-4 shows the relationship between this point and the load.

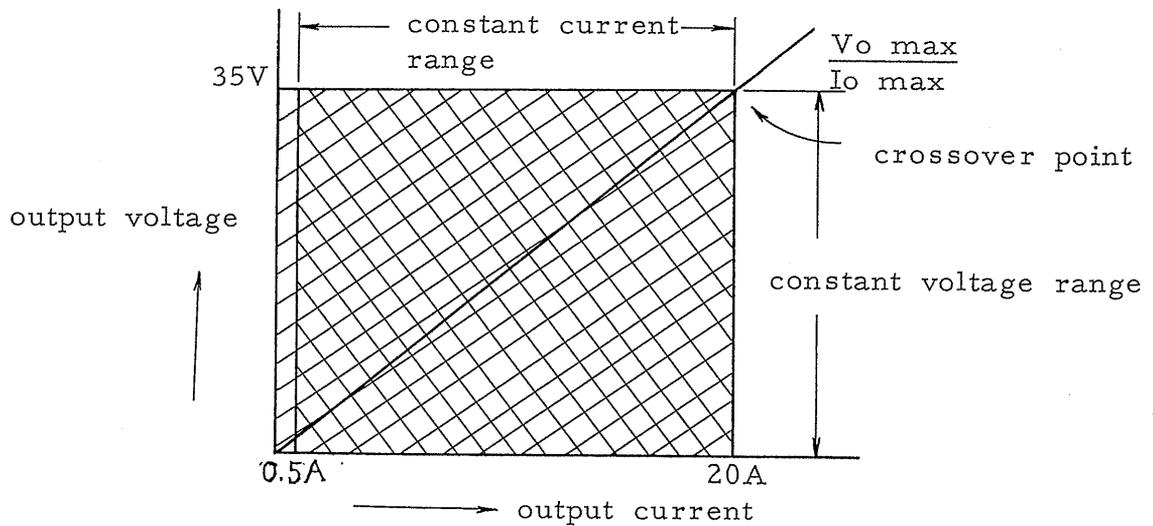

Fig. 3-4

The operation modes of PAD35-20 are indicated by the area with oblique lines.

Operation is possible anywhere within this area.

3.5 Transient response

Designed to meet a transient response quickly enough, PAD35-20

can be used for digital or other circuits involving a drastic load variation and in which performance is affected by a transient variation. But this is the characteristic at the output terminals, and if a long lead is extended to the load, then influence of the inductance is not negligible.

In such a case, use capacitors to cancel the inductance.

3.6 Single operation

Constant voltage performance

- 1) Connect the power cord. Throw the power switch upwards, and Model PAD35-20 is ready to operate immediately, lighting the pilot lamp simultaneously.
- 2) Turn CURRENT knob fully clockwise. Turn VOLTAGE knob until the desired voltage is obtained. (Clockwise rotation increases the output voltage.)
- 3) Connect the output terminals to the load.

Note: When requiring limiting the load current to a certain value, Before the load connect, short the output terminals. Set "CURRENT" knob to the desired current value.

Constant current performance

- 1) The same as Paragraph #1) in "Constnat voltage performance"

above.

- 2) Turn "VOLTAGE" knob clockwise until its motion becomes slightly rough. (This implies the maximum output voltage.)
- 3) Short the output terminals. Turn "CURRENT" knob until the desired current value is obtained. (Clockwise rotation increases the output current.)
- 4) The same as Paragraph 3) in "Constant voltage performance" above.

Note 1 Model PAD35-20 is a constant voltage-current automatic crossover type. When the load current is smaller, the constant current mode is changed over to the constant voltage mode at a specific voltage. Thus, when requiring limiting the output voltage to a certain value, preset the output voltage to the desired value.

Note 2 The constant voltage or constant current mode is indicated by the respective lamps on the front panel alternately.

Constant current mode lamp C.C

Constant voltage mode lamp C.V

Note 3 For use of the sampling terminals, see Note 3 in Chapter 3.4 "How to use sampling terminals".

3.7 Series Connection

A higher output voltage than 35V can be obtained by connecting two Model PAD35-20s in series.

Note 1 Be careful not to ground the positive terminal of one Model PAD35-20 when grounding the negative terminal of the other in Fig. 3-5.

Note 2 The voltage at each output terminal should not exceed the floating voltage.

Note 3 Avoid the series connection with other model.

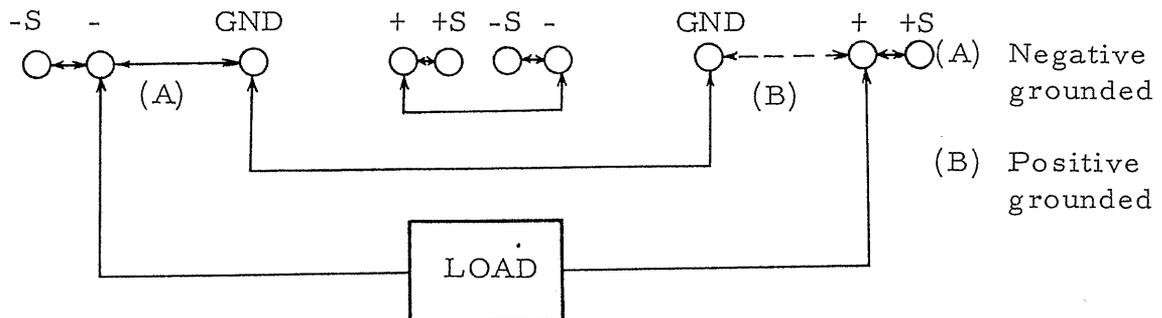

Fig. 3-5 Series connection diagram

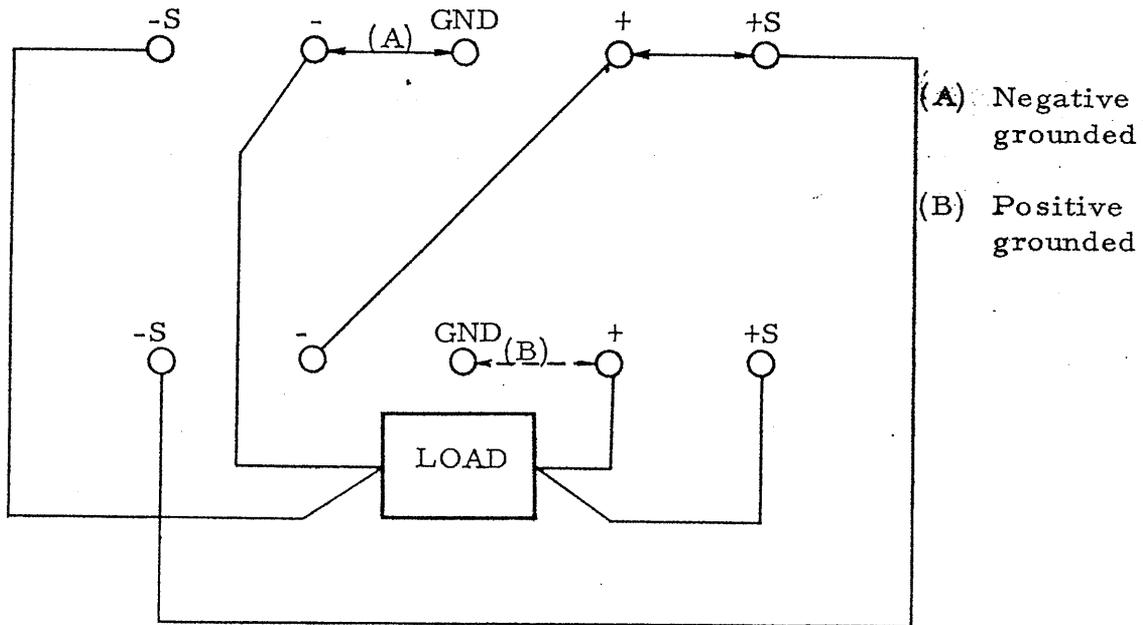

Fig. 3-6 Sampling terminal connection diagram in series connection

When two Model PAD35-20 connected in series are overloaded, one Model PAD35-20, which has been changed over to the constant current mode first, would be supplied with the output voltage of the other inversely.

This would damage series transistors of the former.

To avoid this trouble, a diode is connected between the output terminals of each Model PAD35-20, as shown in Fig. 3-7.

Patent pending No. 308280.....

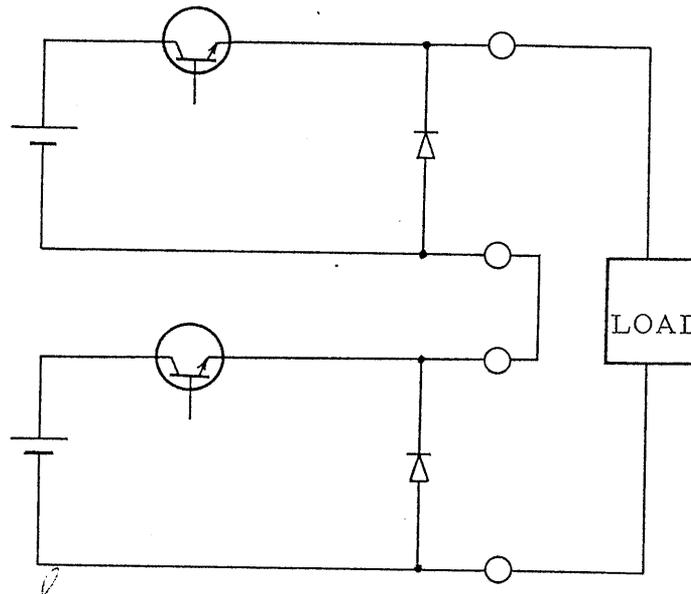

Fig. 3-7

3.8 Parallel Connection

When a larger current than 20A is required, connect the output terminals of two Model PAD35-20 in parallel.

- 1) Set the output voltages of the two Model PAD35-20 in parallel connection at values as close as possible each other since a setting difference between the two would cause load fluctuation.
- 2) Turn "CURRENT" knobs fully clockwise.
- 3) Connect the output terminals of two Model PAD35-20 to the load so that their polarity matches.

The grounding polarity of both should also match.

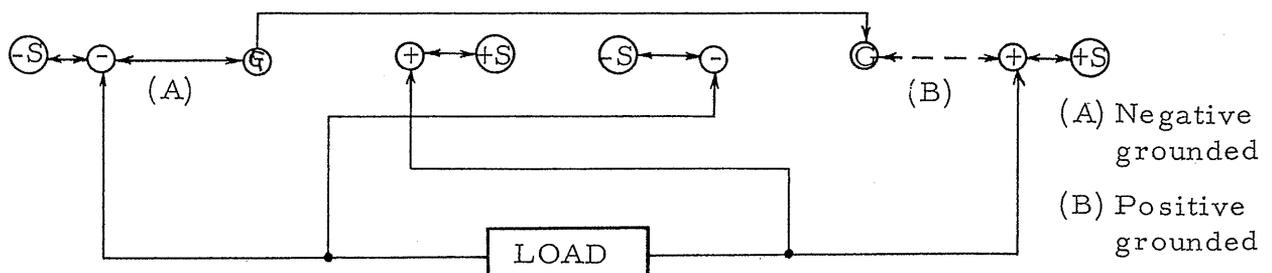

Fig. 3-8 Parallel connection diagram

Voltage-current characteristics in parallel connection

As the voltage-current characteristics in parallel connection in Fig. 3-9 show the output voltage in parallel operation remains constant until one Model PAD35-20 with a higher output voltage is overloaded. When one Model PAD35-20 is changed over to the constant current mode, the output voltage decreases until it reaches the value preset by the other Model PAD35-20, whose output terminals are changed over from an inverse voltage condition to a normal one, causing the constant voltage mode. Thus, load fluctuation causes the output voltage to fluctuate by the preset output voltage difference ΔV between the two units, and ripple characteristics are reduced.

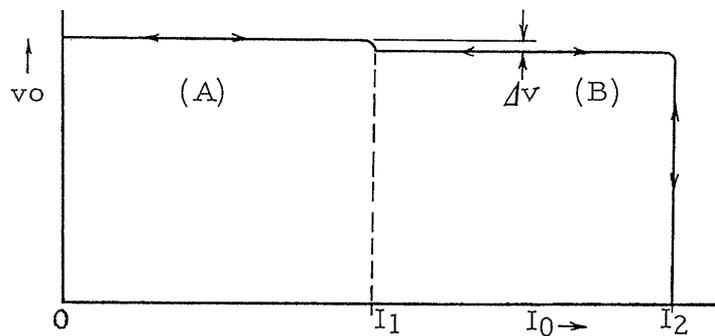

Fig. 3-9 Characteristics diagram

3.9 One-control parallel operation

When a larger current than 20A is required, one-control parallel operation of two Model PAD35-20 is preferable since the

characteristics are improved largely, as compared with those in parallel connection.

In one-control parallel operation, one of the Model PAD35-20 operates as the master unit, by which the output voltage is adjusted, and the other as the slave whose output voltage is controlled by the master unit.

- 1) Connect the terminals on the rear panel of the master to the slave and the load as shown in Fig. 3-10.
- 2) Pick up the output at the output terminals on the rear panel of the master. When turning on the power or output switches of the master and slave, start with the master.

When turning them off, start with the slave.

Note 1 Picking up the output on the output terminals on the front panel of the master causes load regulation to be deteriorated somewhat, and current unbalance occurs between the master and slave.

Note 2 To prevent load regulation from increase, use the sampling terminals. (Connection is shown ^{n in} ~~ed~~ Fig. 3-11)

Note 3 Turn "VOLTAGE, CURRENT" knob of the slave fully clockwise.

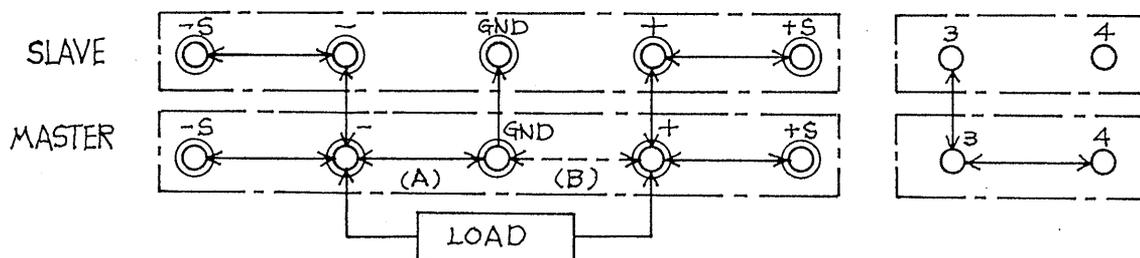

Fig. 3-10 One-control parallel operation master, slave, load

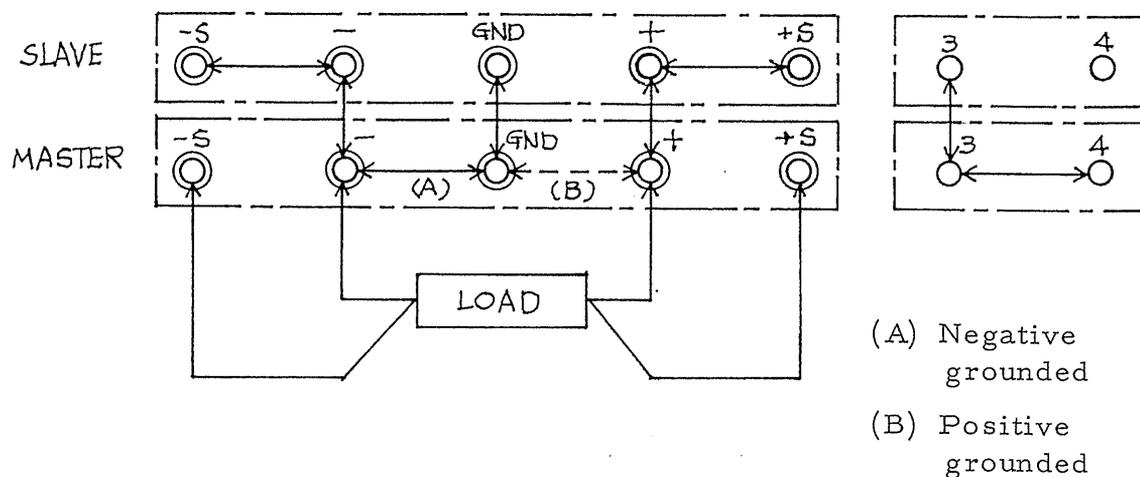

Fig. 3-11 Using sampling terminal in one-control parallel operation

3.10 Remote control

To vary output voltage by remote control, improve efficiency in varying output voltage and obtain the preset output voltages simply by operation of switches or others, use the remote control terminals on the rear panel.

- 1) Turn off power switch and remove jumpers from

terminals ① and ② on the rear panel.

2) Provide a suitable variable element between ① and -S

Note Variable element will be described in detail later.

3) Turn on power switch and then output voltage will vary according to the characteristic of the variable element connected.

Note If the line connected to variable element is open, output voltage cannot be controlled, and excessive output voltage is detected. Make the connection with power switched off.

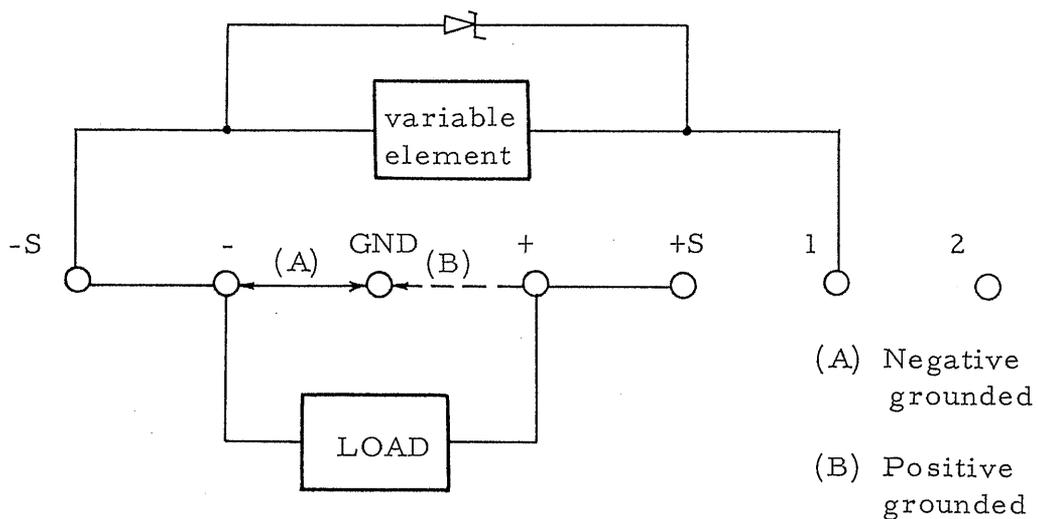

Fig. 3-12

3.10-1 To vary output voltage by remote control.

Output voltage varies at a rate of approximately 3.5V/k ohms with reference to the resistance of the resistor connected. Therefore,

$$\text{output voltage } V_o(V) = \text{Voltage variation rate } 3.5V/k \text{ ohms} \\ \times R_r [k \text{ ohms}]$$

where voltage variation rate indicates voltage change for each 1 k ohms, and R_r the resistance [k ohms] for remote control.

If no suitable resistor is available and output V_o may exceed the rated output or it is desired to fix voltage at a certain level, output voltage can be limited by connecting zener diode with a small leakage current to the resistor.

(See Fig. 3-12)

Note Use a wire wound type variable resistor with a low temperature coefficient or a metal-film one, and the power rating of such a resistor must be at least 0.5W more over.

Otherwise, the temperature drift of output voltage may deteriorate.

Note PAD35-20 can operate steadily if the external lines connected are limited to approximately 2m.

If longer lines are used, output voltage may become unstable.

3.10-2 To improve efficiency in varying output voltage (to finely adjust voltage).

As already mentioned, output voltage is proportional to the external resistance.

Letting V_{res} stand for the required efficiency, the efficiency of the resistor can be formulated as follows.

$$R_{res} = \frac{V_{res}}{\text{Voltage variation rate } 3.5V/k \text{ ohms}} \text{ [k ohms]}$$

3.11 Internal temperature detector circuit

When the internal temperature exceeds 75°C, the built-in circuit automatically shuts off the output circuit.

Therefore, if this instrument is used in a place where the ambient temperature is over 40°C, or used by mounting it on another instrument, the entire output or current may not be obtained. Since this circuit is restored to its original condition soon after the internal temperature lowers below the specific value, turn off the power switch, and cool the instrument if the output cannot be obtained as specified while the circuits operate normally.

4. ADJUSTING PROCEDURE

4.1 Adjustment of maximum output voltage

- 1) Turn VOLTAGE knob to clockwise over 5 turns.
- 2) Turn on OUTPUT switch, and connects a voltmeter having an accuracy of over 0.5% to the output terminal.
- 3) Adjust semi-fixed resistor R10 on PCB A-001A until the output voltage becomes 37V.

4.2 Adjustment of maximum output current

- 1) Turn VOLTAGE knob fully counterclockwise.
- 2) Turn CURRENT knob fully clockwise.
- 3) Connect an ammeter having an accuracy of over 0.5% to the output terminals, and slowly increase the voltage by turning VOLTAGE knob.
- 4) Turn semi-fixed resistor R14 on PCB A-001A until the output current becomes 20.5A

4.3 Adjustment of voltage across the collector and the emitter of series transistors

- 1) Turn the CURRENT knob until the output current becomes 20A under the 4.2 condition.
- 2) Adjust the semi-fixed resistor R101 on PCB A-004A until the

collector voltage of the series transistors Q8 ~ Q15
becomes 7V under this condition.

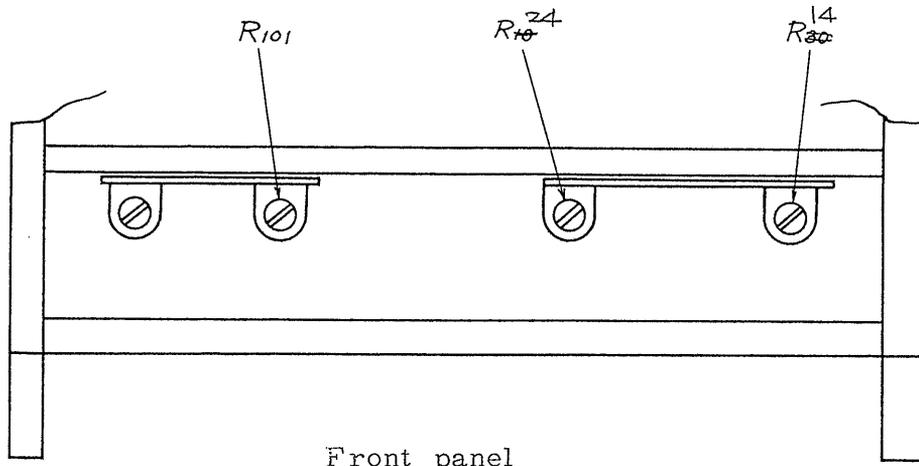

Front panel

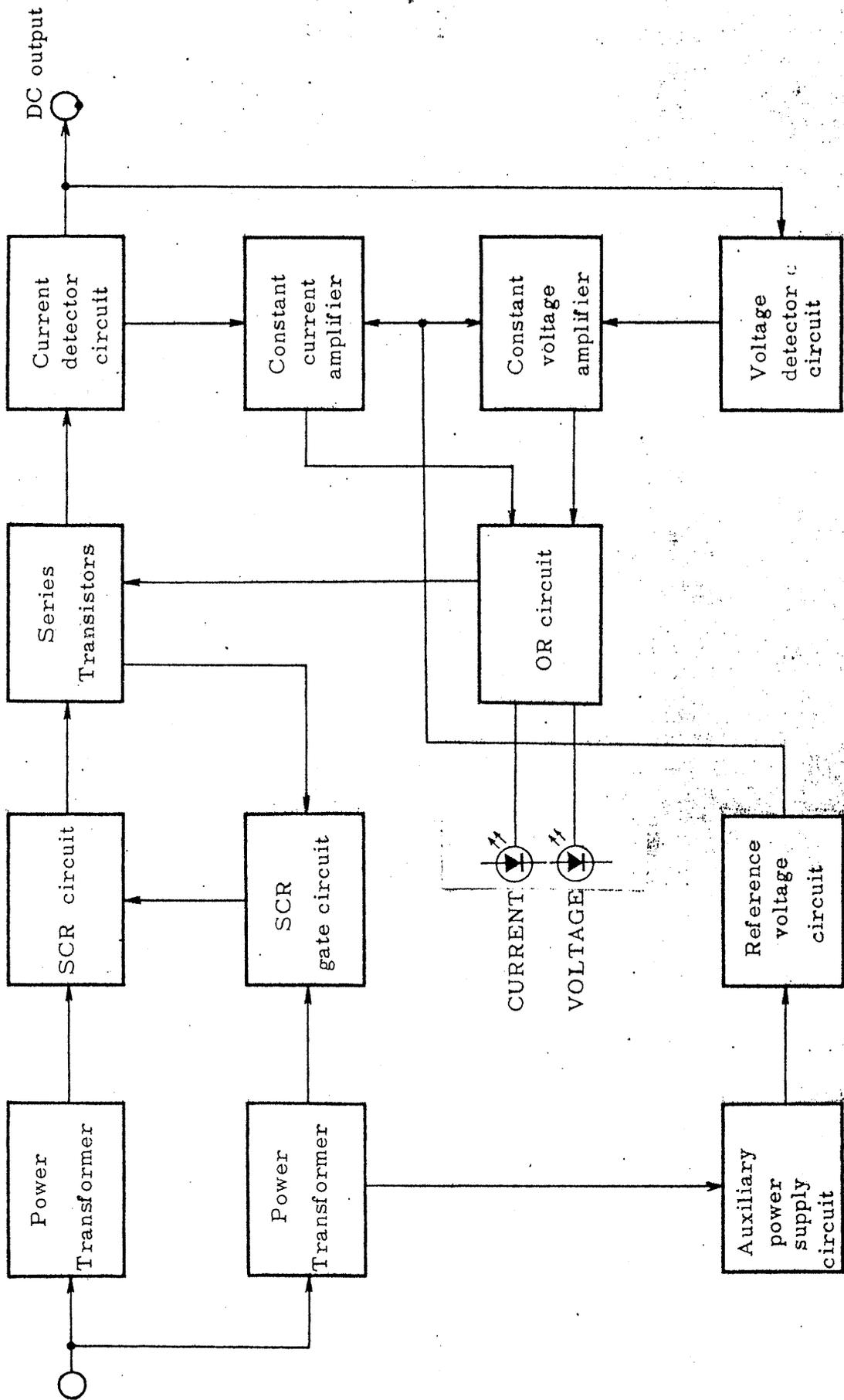

z Fig. 4-1 Block diagram